

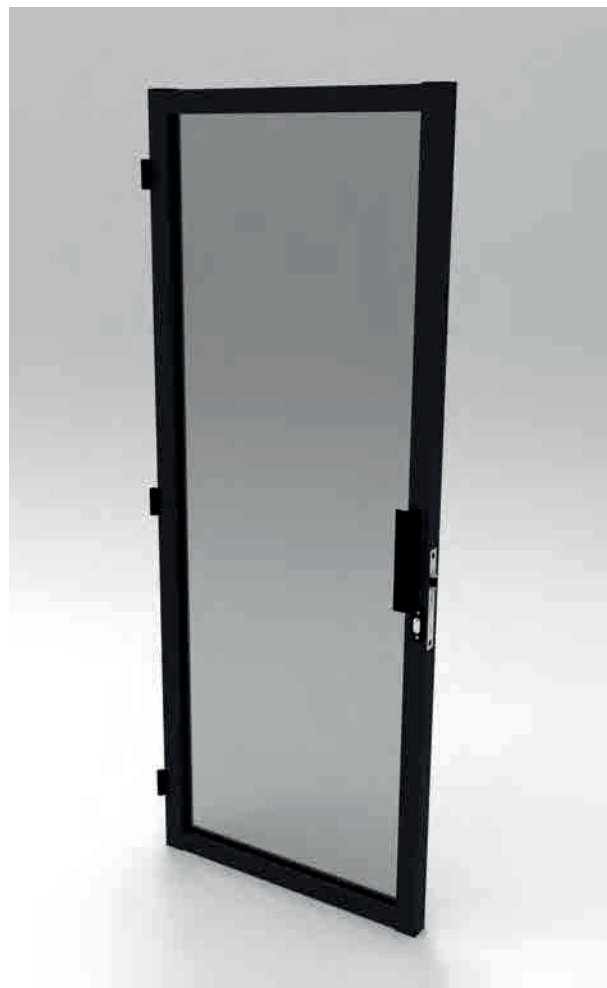

**Montage porte avec serrure à rouleau**  
profils porte ouvrante 40 - 40

- Porte battante avec Profils porte ouvrante 40 / 40
- Serrure à rouleau seule ou serrure à rouleau avec pêne dormant
  - Demi-cylindre 10x35 (ovale) avec 3 clés
  - Poignée de tirage

Fermeture à clé SEULEMENT côté charnière avec le pêne demi-cylindre

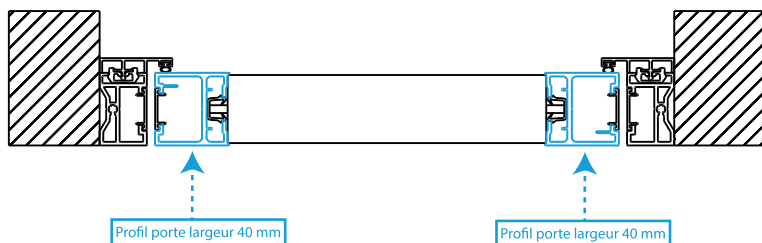

**Montage porte avec béquille**  
profils porte ouvrante 40 - 66

- Porte battante avec Profils porte ouvrante 40 / 66
- Serrure pêne 1/2 tour et pêne dormant
  - Cylindre entier 35x35 (européen) avec 3 clés
  - Béquilles + rosaces ovales

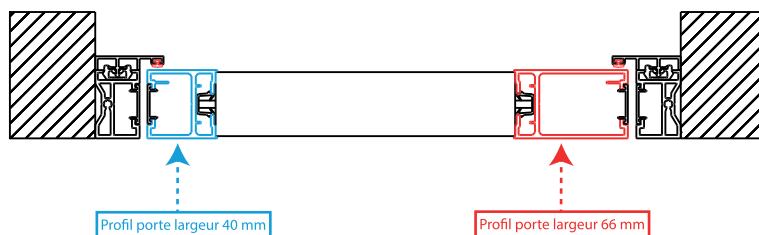

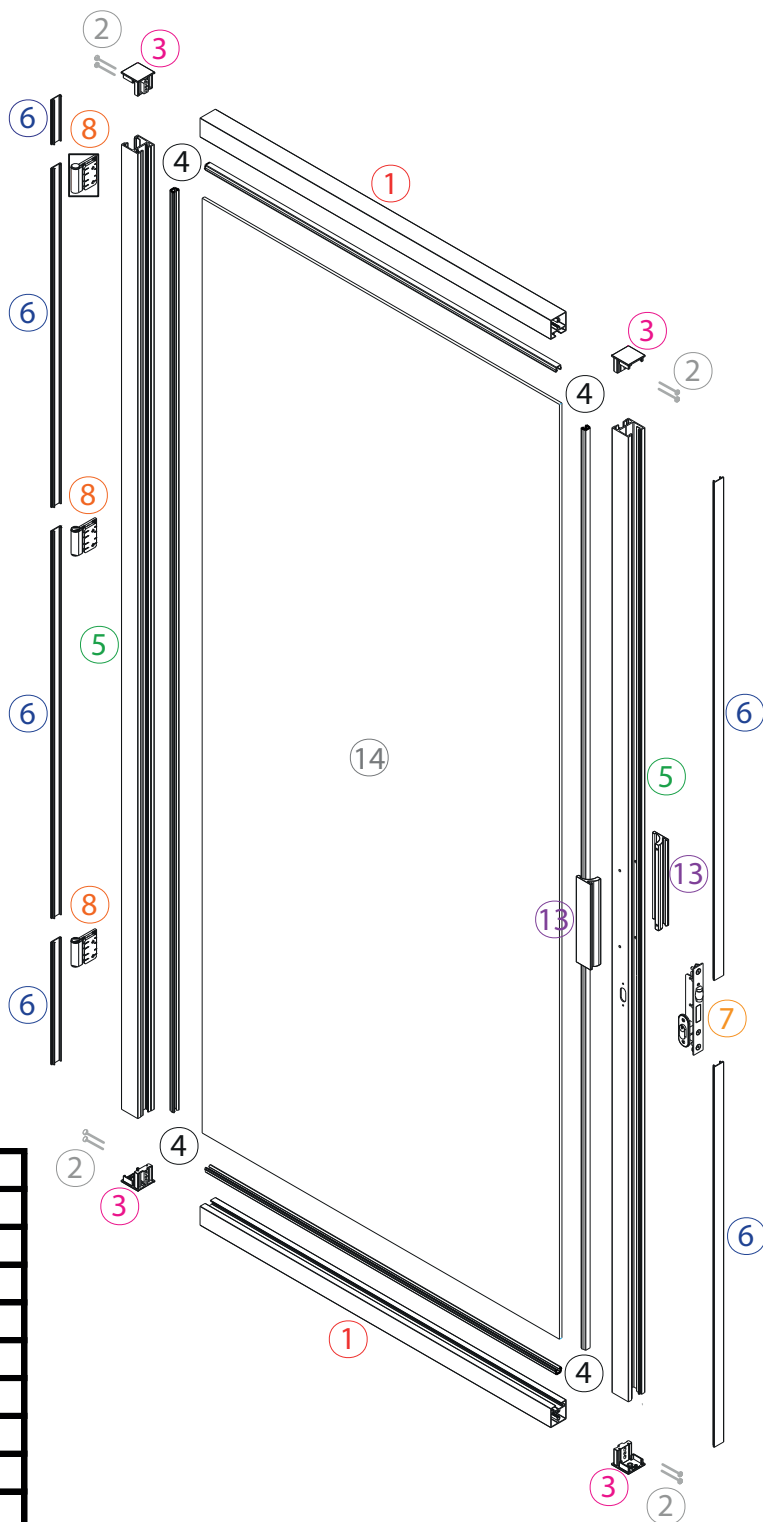
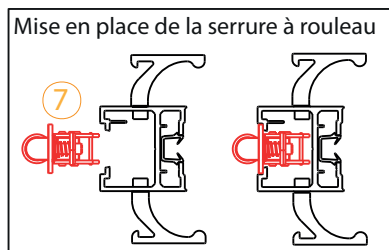
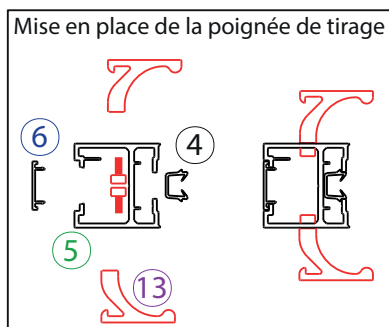
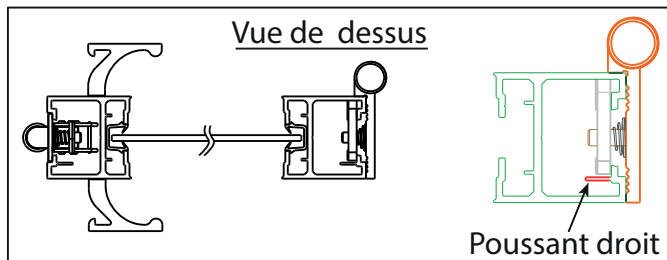
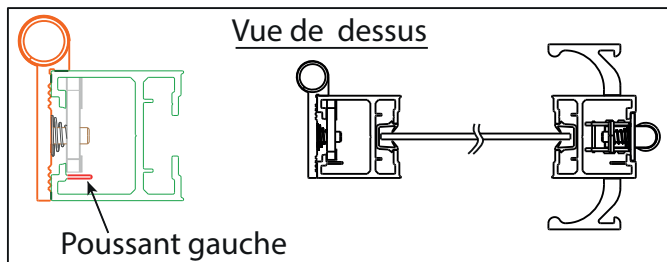

| N° | Qté | Désignation                                 |
|----|-----|---|
| 1  | 2   | Profil traverse haute et basse 40           |
| 2  | 8   | Vis 4,8x50 auto foreuse                     |
| 3  | 4   | Capot d'assemblage porte ouvrante 40        |
| 4  | 4   | Profil de vitrage 6/8                       |
| 5  | 2   | Profil porte ouvrante 40                    |
| 6  | 6   | Profil plat de finition 23                  |
| 7  | 1   | Serrure à rouleau avec pêne + demi-cylindre |
| 8  | 3   | Paumelle supérieur                          |
| 13 | 2   | Poignée de tirage + vis                     |
| 14 | 1   | Remplissage 6/8                             |

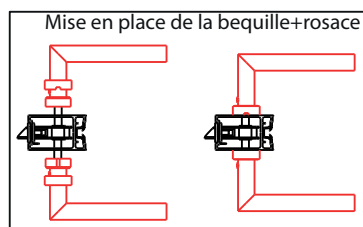
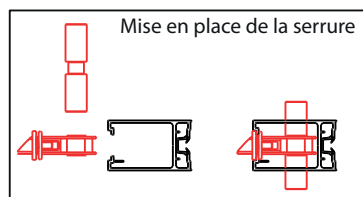
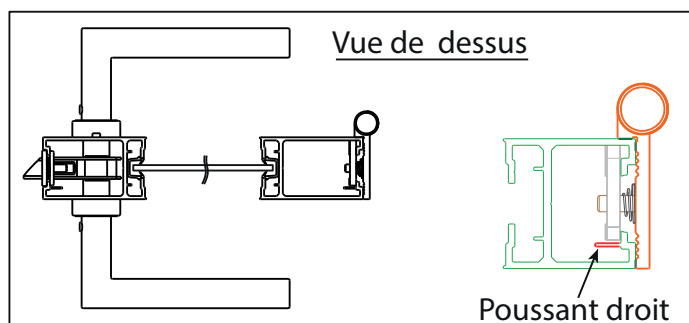
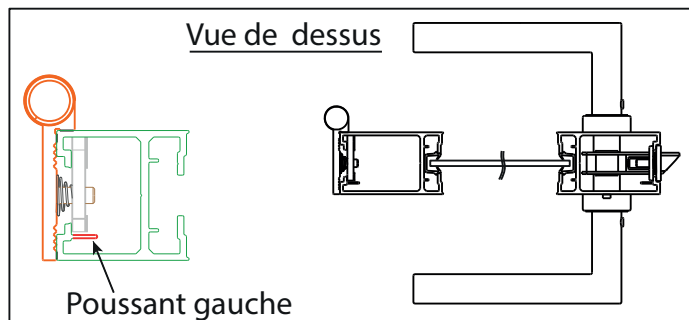

| N°    | Qté | Désignation                          |
|-------|-----|--------------------------------------|
| 1     | 2   | Profil traverse haute et basse 40    |
| 2     | 8   | Vis 4,8x50 auto foreuse              |
| 3     | 2   | Capot d'assemblage porte ouvrante 40 |
| 3 bis | 2   | Capot d'assemblage porte ouvrante 66 |
| 4     | 4   | Profil de vitrage 6/8                |
| 5     | 1   | Profil porte ouvrante 40             |
| 5 bis | 1   | Profil porte ouvrante 66             |
| 6     | 6   | Profil plat de finition 23           |
| 7     | 1   | Serrure pêne demi-tour + cylindre    |
| 8     | 3   | Paumelle supérieur                   |
| 13    | 2   | Béquille + Rosace ovale              |
| 14    | 1   | Remplissage 6/8                      |

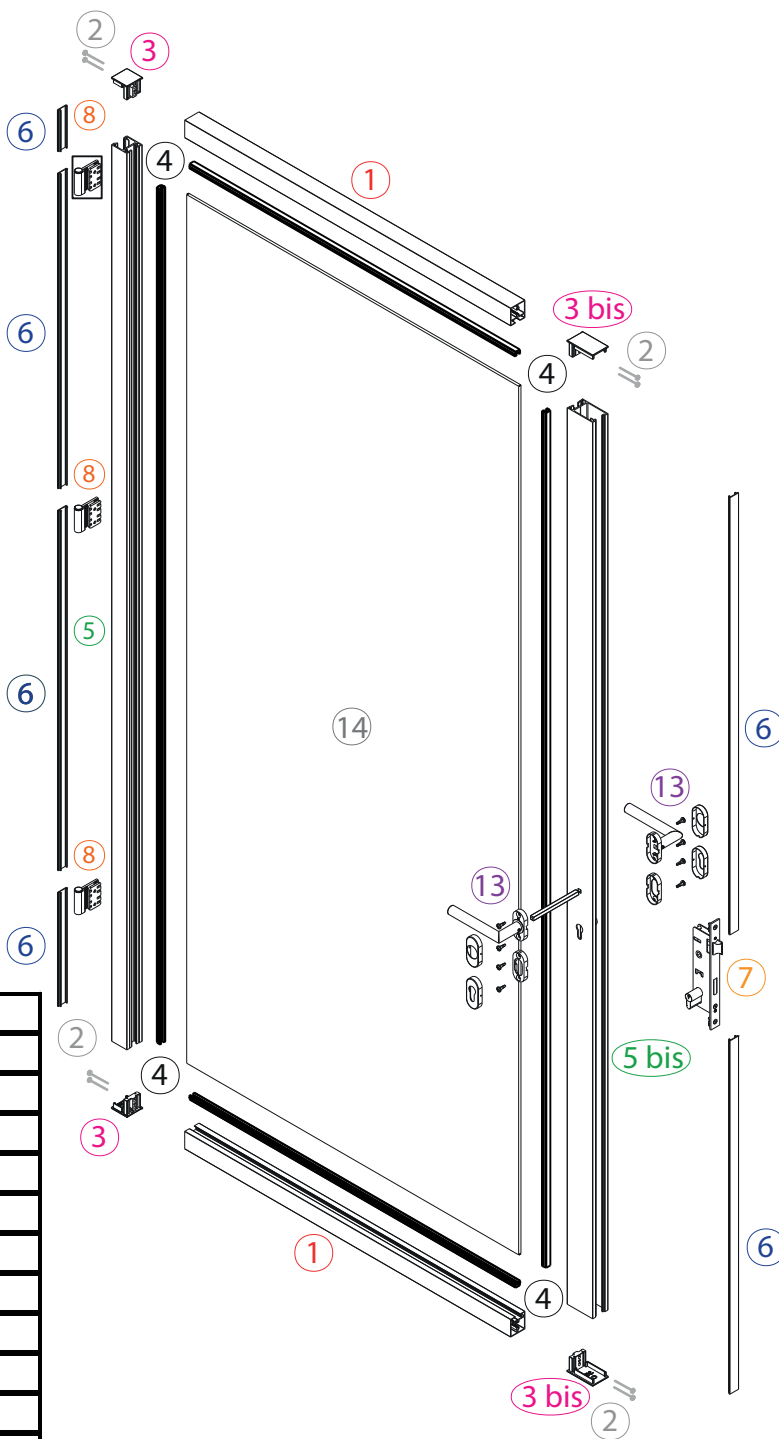

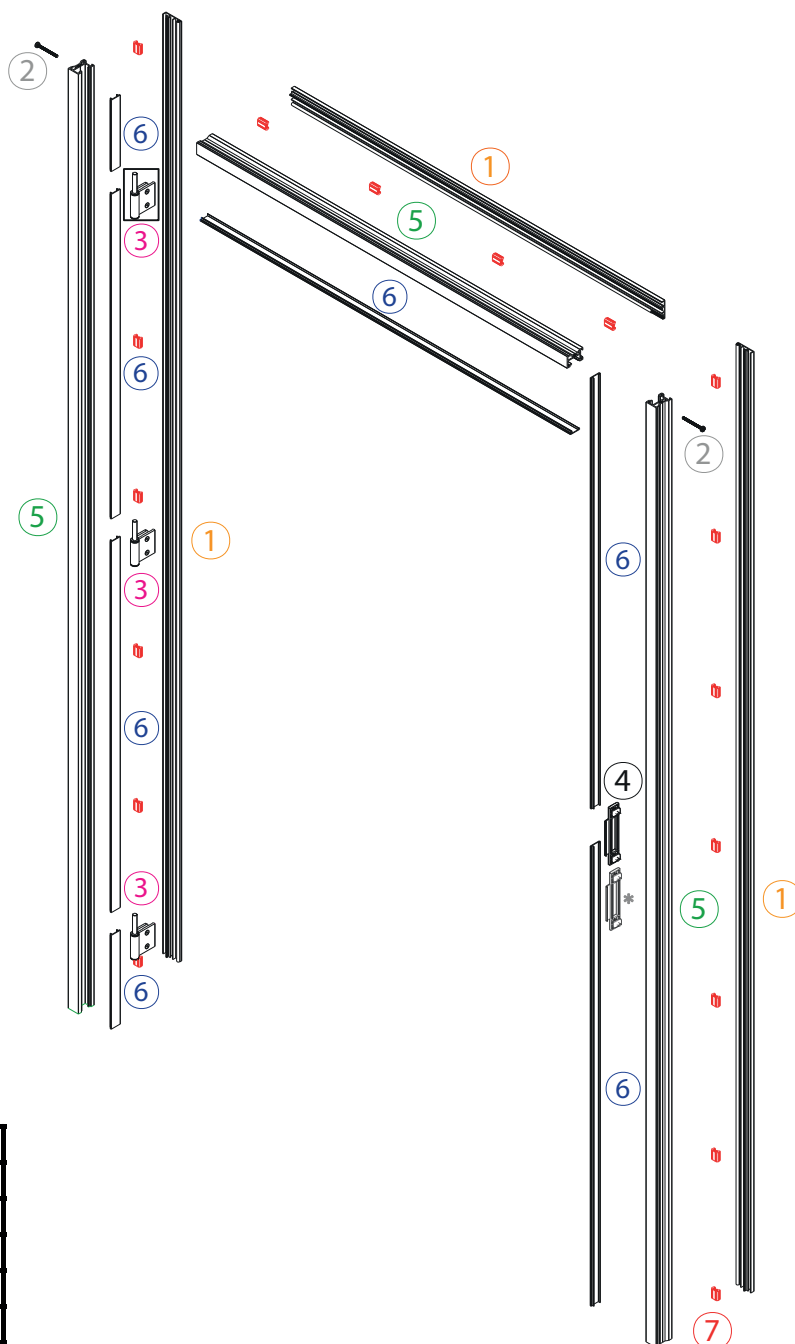
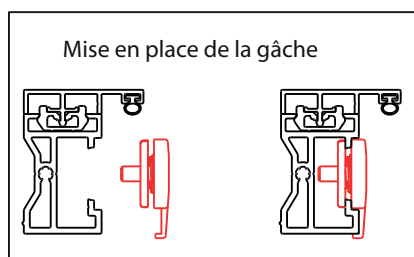
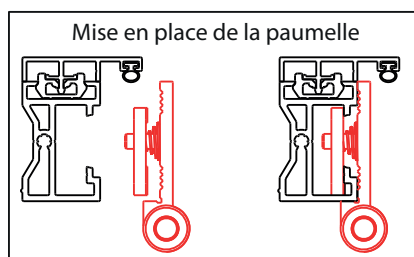
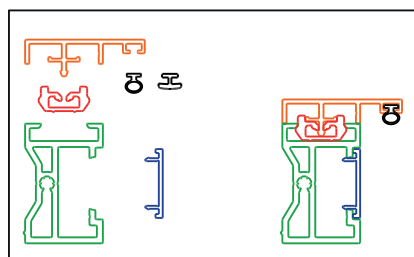

| N° | Qté | Désignation                |
|----|-----|----------------------------|
| 1  | 3   | Profil parclose dormant 26 |
| 2  | 2   | Vis 4,8x50 auto foreuse    |
| 3  | 3   | Paumelle inférieur         |
| 4  | 1*  | Gâche de fermeture         |
| 5  | 3   | Profil dormant 26          |
| 6  | 7   | Profil plat de finition 23 |
| 7  | 18  | Clips                      |

\* 2 gâches si serrure avec pêne demi-tour et dormant (béquille)



|   |  |  |  |
|---|--|--|--|
| <b>PROFIL DORMANT 26</b>                    |  | <b>PAUMELLE COMPLETE</b>                               |  |
|   |  |  |  |
| <b>PROFIL PARCLOSE DORMANT 26</b>           |  | <b>SERRURE A ROULEAU SEUL OU + PENE + 1/2 CYLINDRE</b> |  |
|   |  |  |  |
| <b>PROFIL PORTE OUVRANTE 40</b>             |  | <b>SERRURE AVEC PENE + CYLINDRE</b>                    |  |
|   |  |  |  |
| <b>PROFIL PORTE OUVRANTE 66</b>             |  | <b>POIGNEE DE TIRAGE - 180MM</b>                       |  |
|   |  |  |  |
| <b>PROFIL TRAVERSE HAUTE ET BASSE 40</b>    |  | <b>BEQUILLES + ROSACES</b>                             |  |
|   |  |  |  |
| <b>PROFIL TRAVERSE INTERMEDIAIRE 28</b>     |  | <b>CLIPS</b>   |  |
|   |  |  |  |
| <b>PROFIL PLAT DE FINITION 23</b>           |  | <b>GACHE DE FERMETURE</b>                              |  |
|   |  |  |  |
| <b>PROFIL DE VITRAGE 6/8</b>                |  | <b>CAPOT D'ASSEMBLAGE PORTE OUVRANTE 40</b>            |  |
|   |  |  |  |
| <b>JOINT D'ETANCHEITE DORMANT</b>           |  | <b>CAPOT D'ASSEMBLAGE PORTE OUVRANTE 66</b>            |  |
|   |  |  |  |
| <b>VIS 4,8X50 AUTO-FOREUSE (Embout PH2)</b> |  | <b>VERROU A ONGLET</b>                                 |  |
|   |  |  |  |

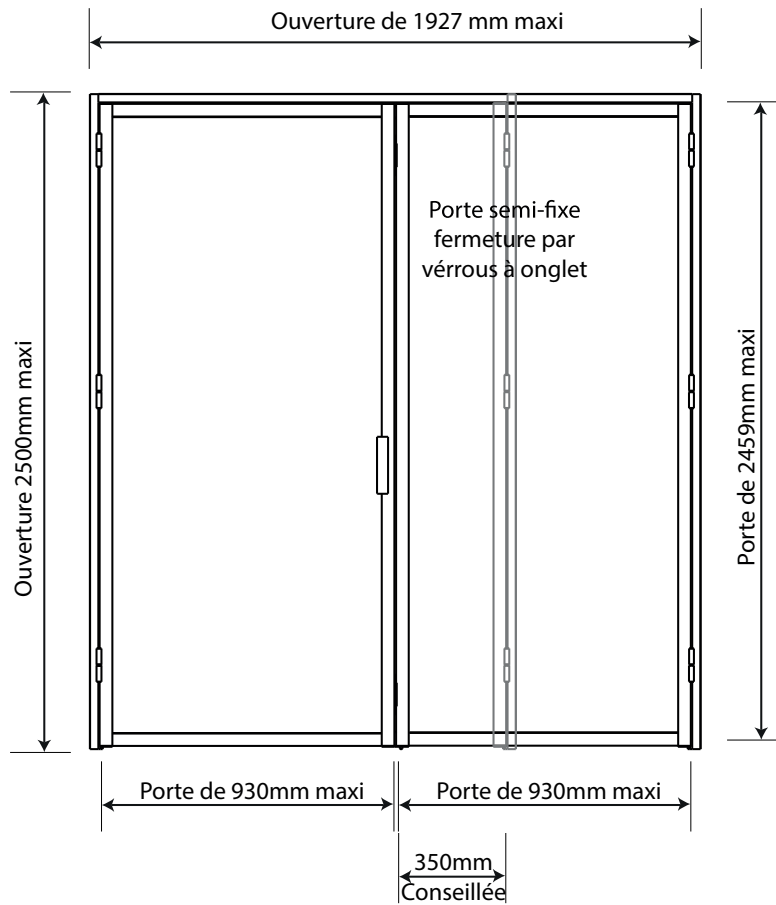

**Montage porte avec serrure à rouleau**  
Profils 40 - 40

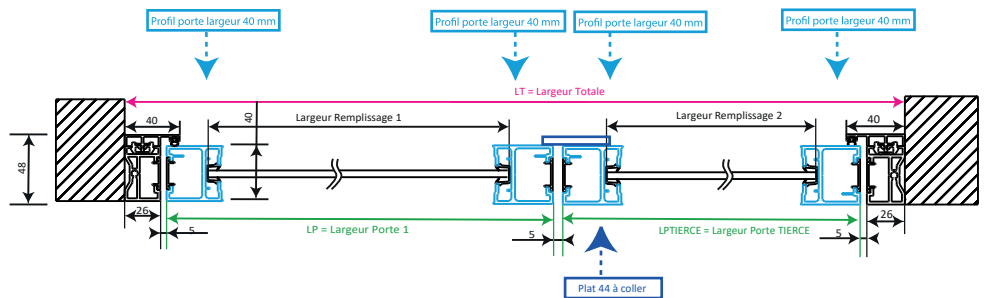

**Montage portes tierce ou double avec béquille**  
Profils 40 - 66

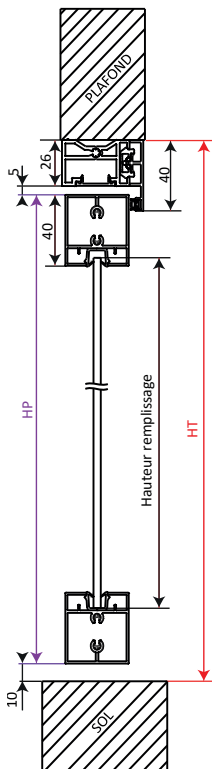
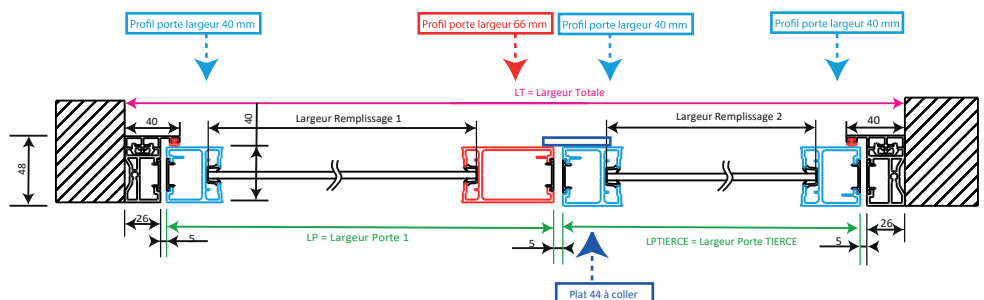



## Largeur Remplissage

Profils 40-40



Largeur Remplissage =  $LP - 62$

Profils 40-66

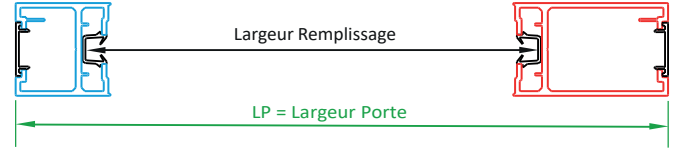

Largeur Remplissage =  $LP - 88$

## Hauteur Remplissage (selon la hauteur sous-traverses)

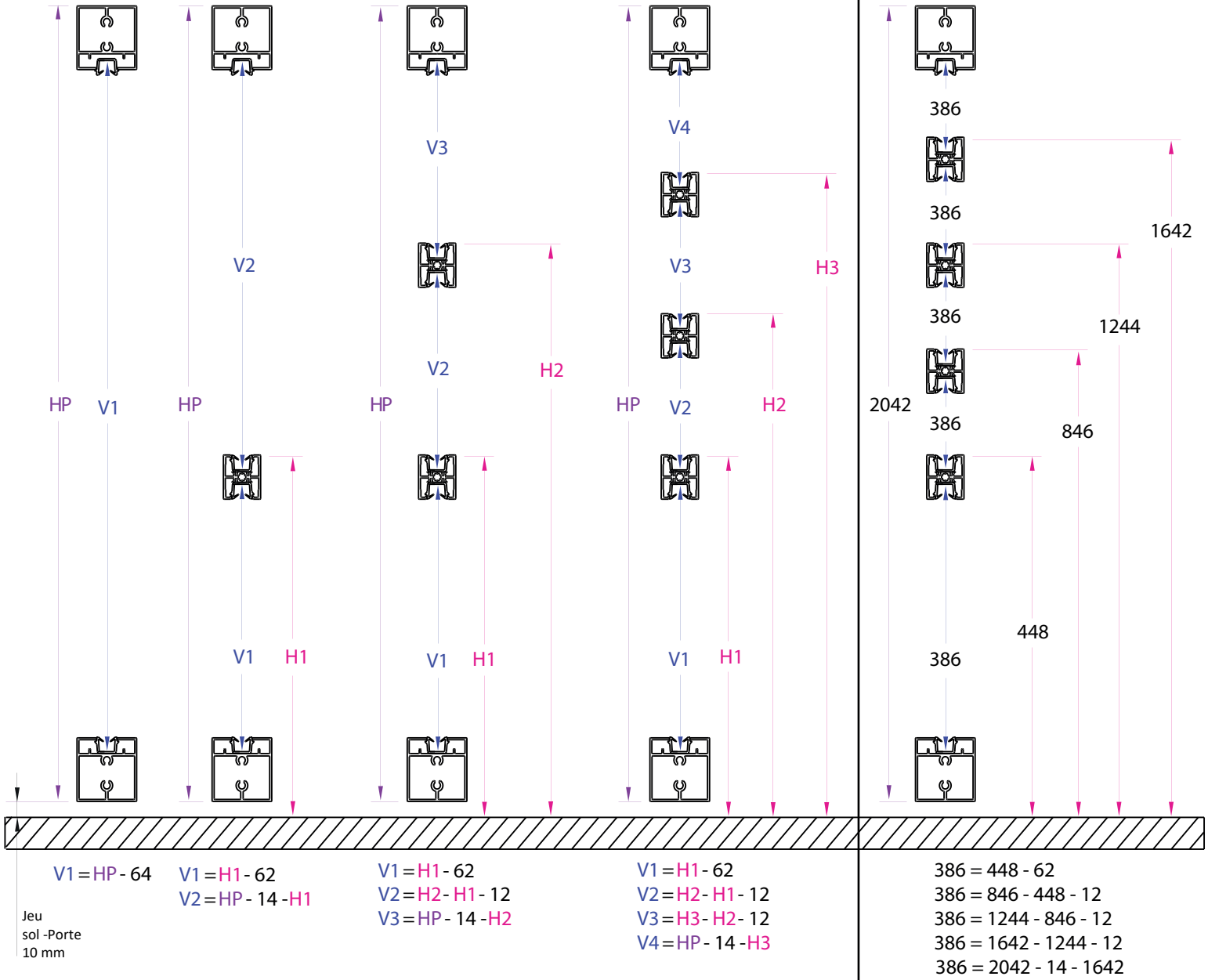



1 - Mise en place des **paumelles inférieures**

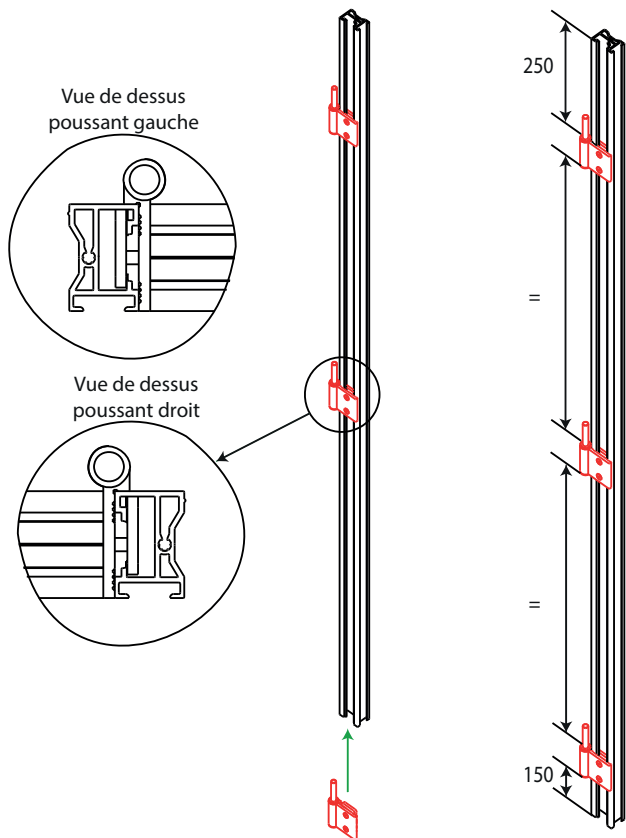

2 - Assemblage DORMANT 26

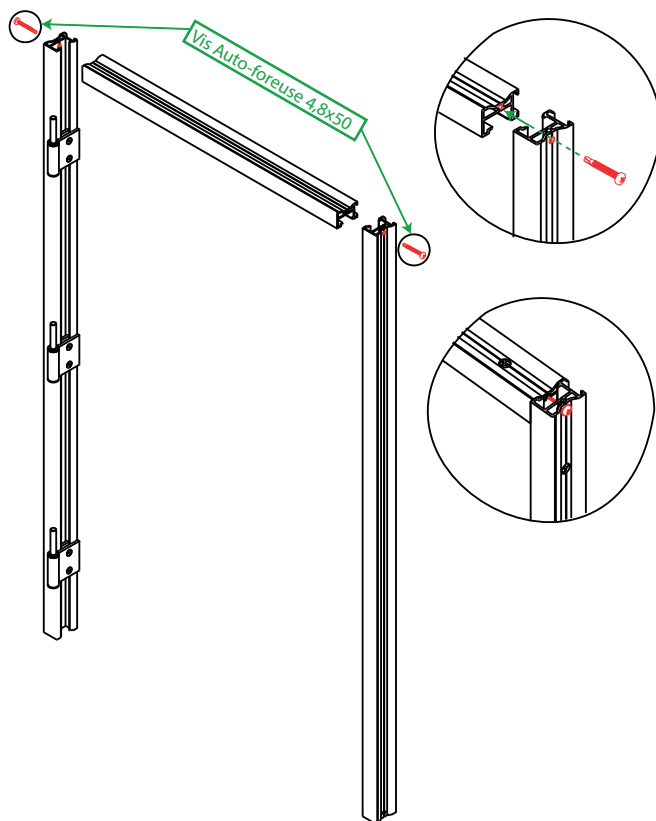

3 - Mise en place de la **gâche** pour la serrure à rouleau avec ou sans pêne

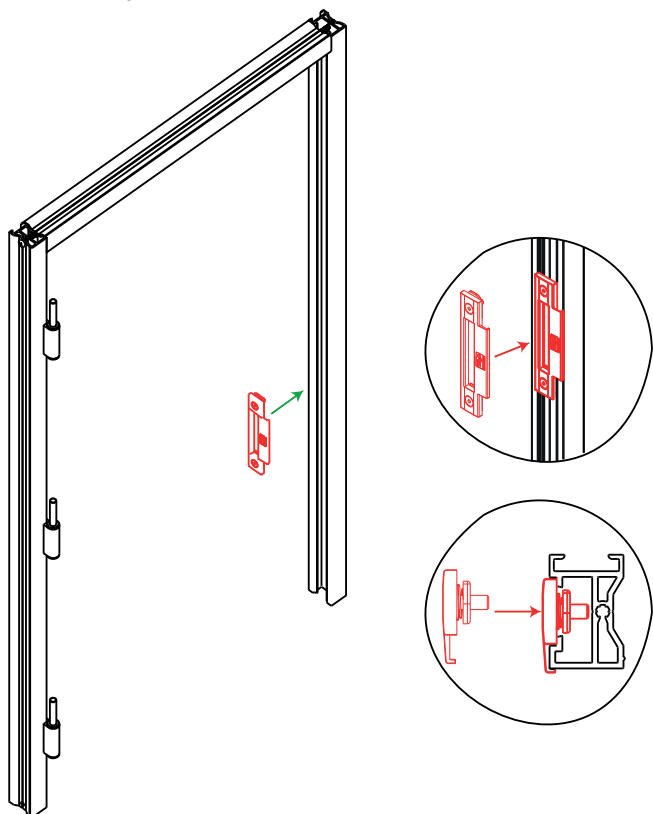

3 - Mise en place de **2 gâches** pour la serrure pêne 1/2 tour + pêne dormant

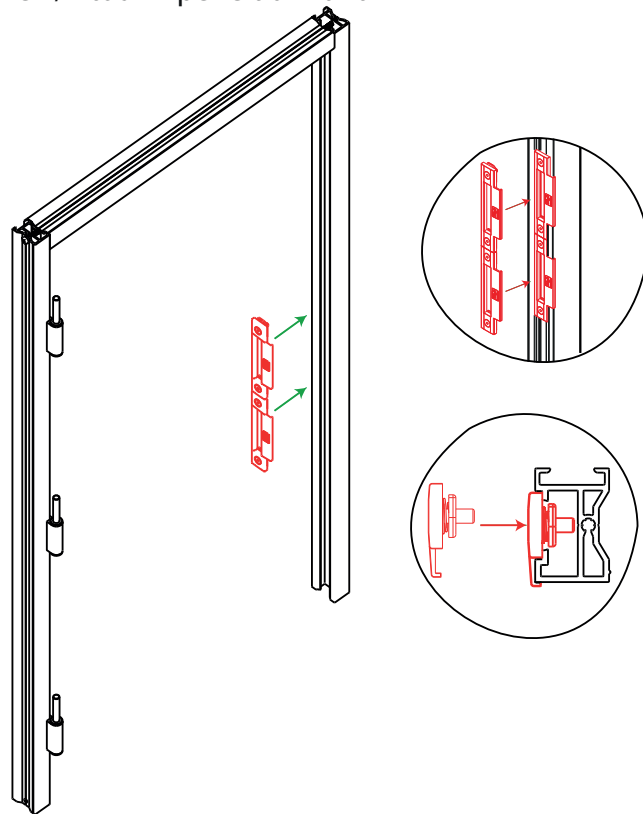





1 - Mise en place **joint de vitrage** sur profil porte 40 et 66

2 - Mise en place **joint de vitrage** sur profil traverse 40

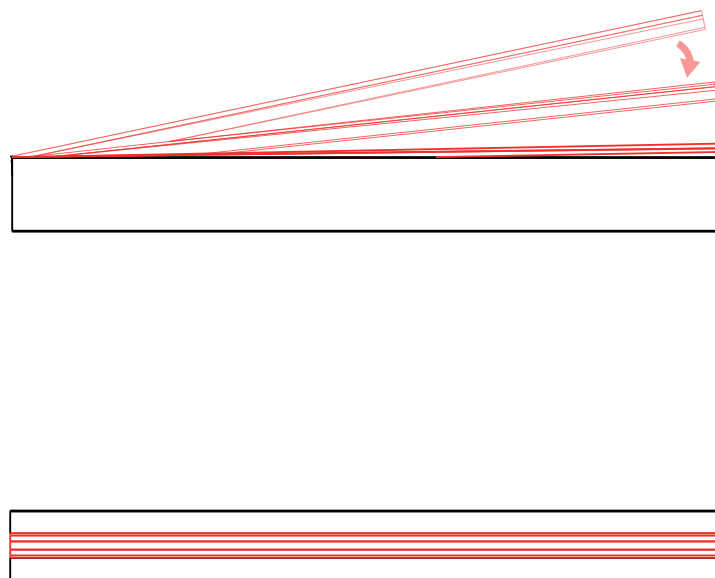
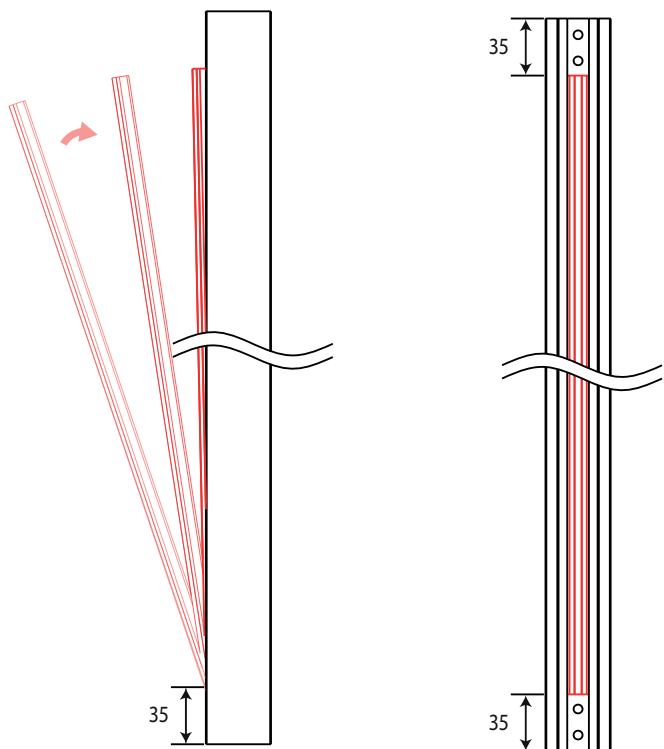

3 - Mise en place des **paumelles supérieures**

4 - Mise en place de la **traverse haute et basse 40**

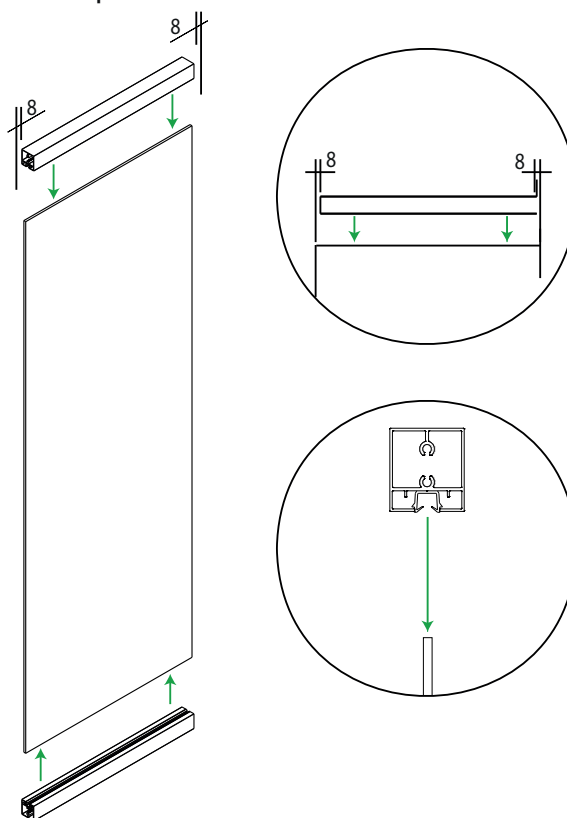
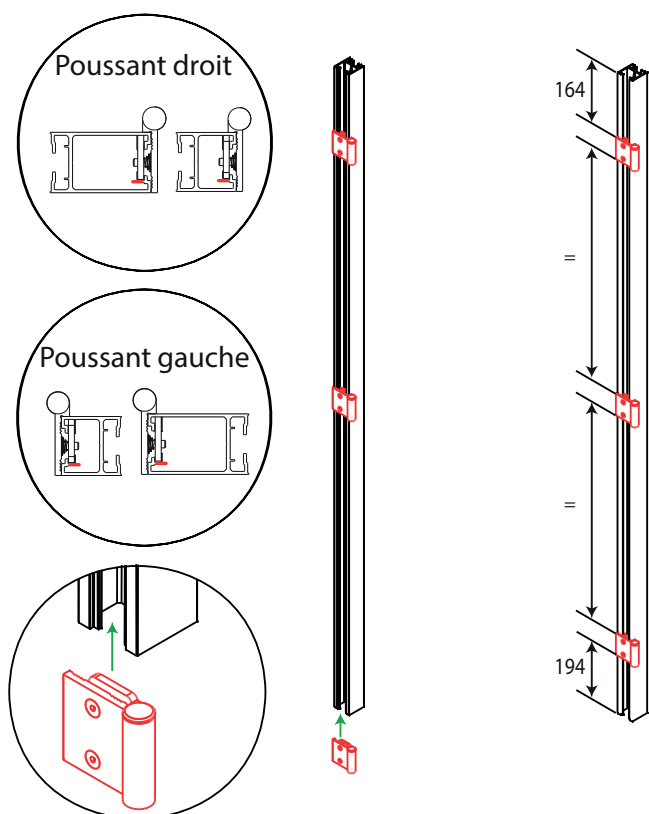



1 - Mise en place des profils porte 40 ou 66

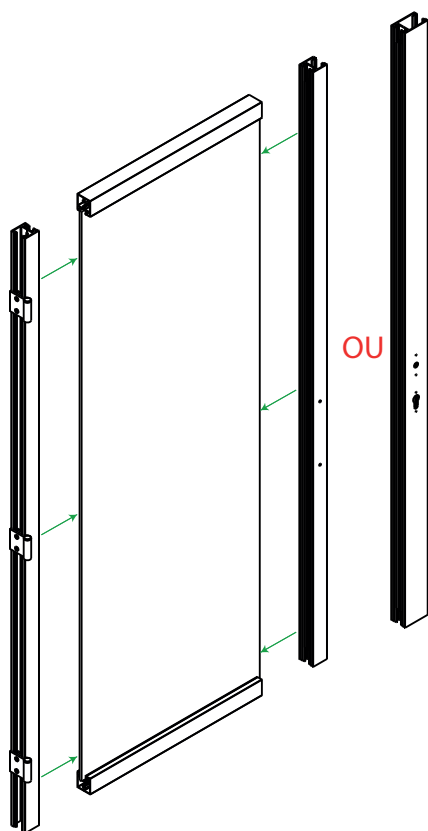

2 - Mise en place des capots d'assemblage porte 40

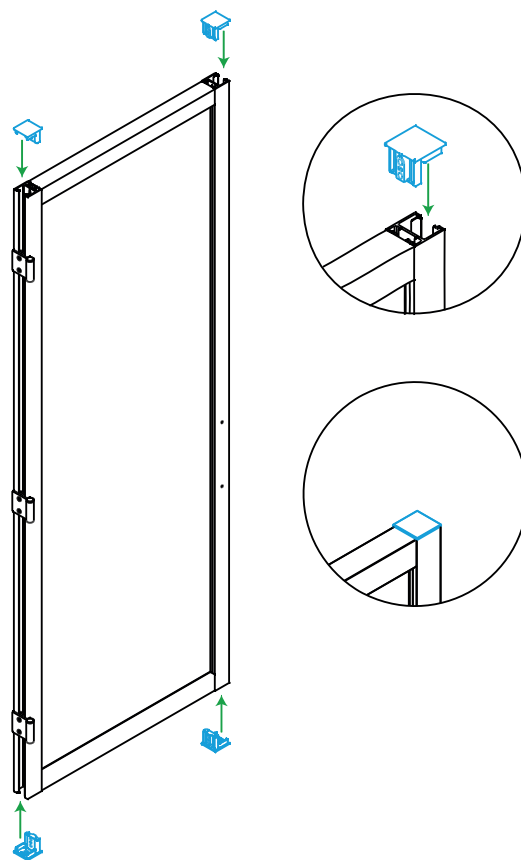

3 - Mise en place des capots d'assemblage porte 40 et 66

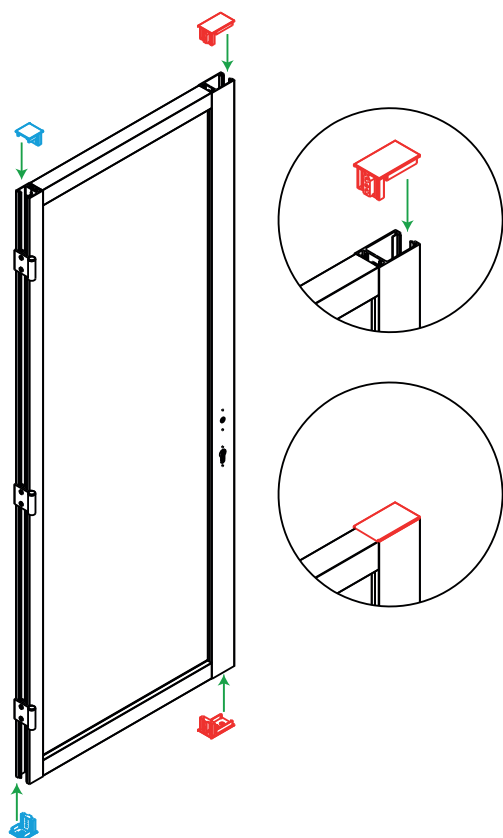

4 - Fixation porte avec vis auto-foreuse 4,8x50 (Embout PH2)

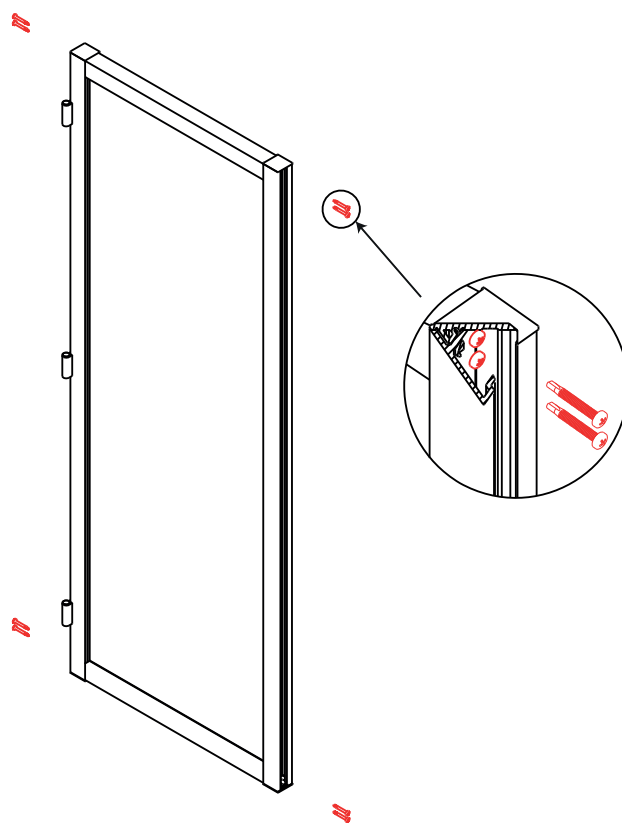



1 - Fixation **poignée de tirage**

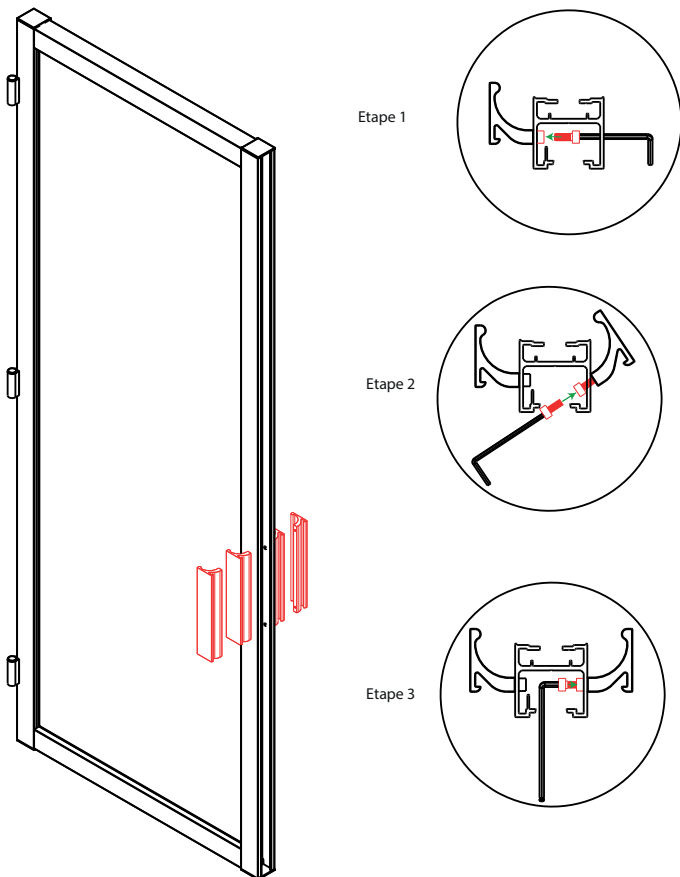

2 - Montage **serrure à rouleau seul**

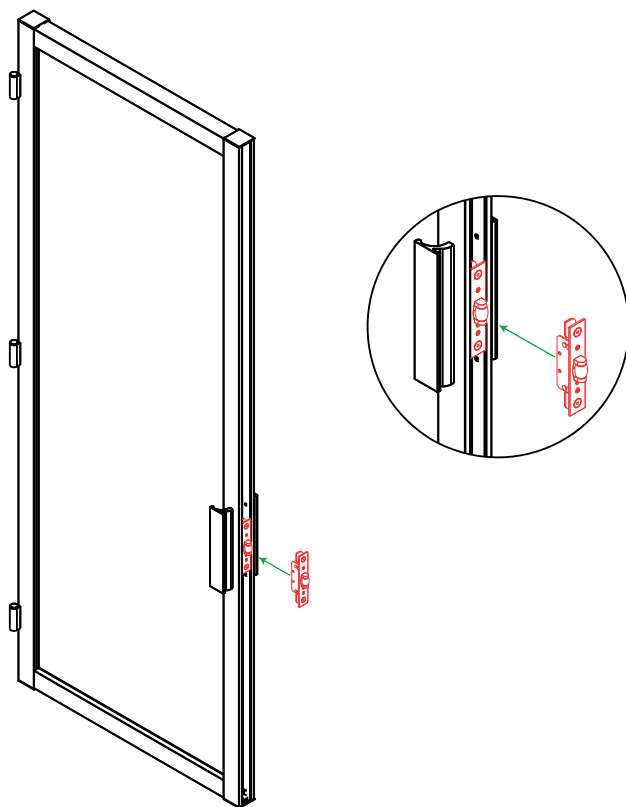

3 - Montage **serrure à rouleau avec cylindre**

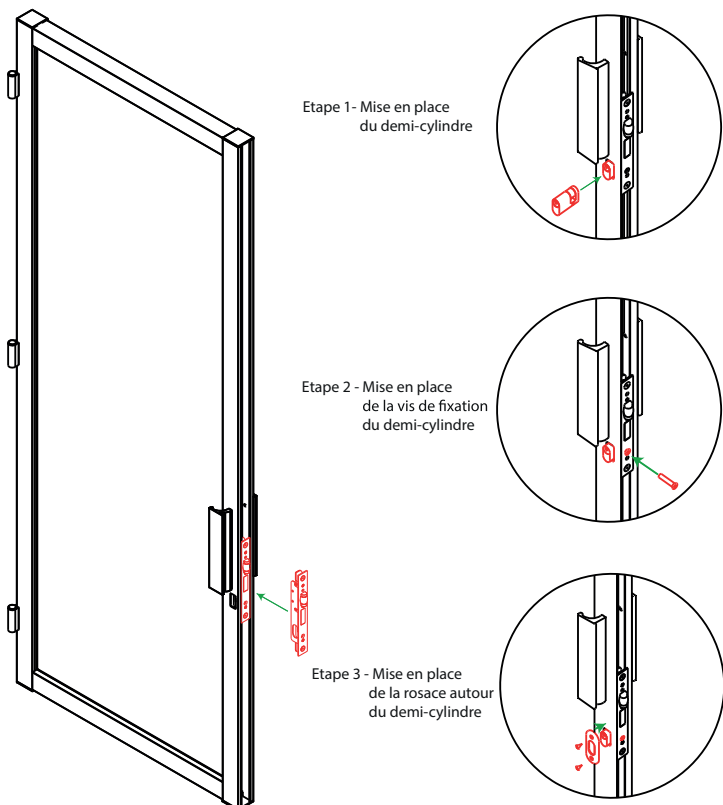

4 - Réglage **serrure à rouleau**

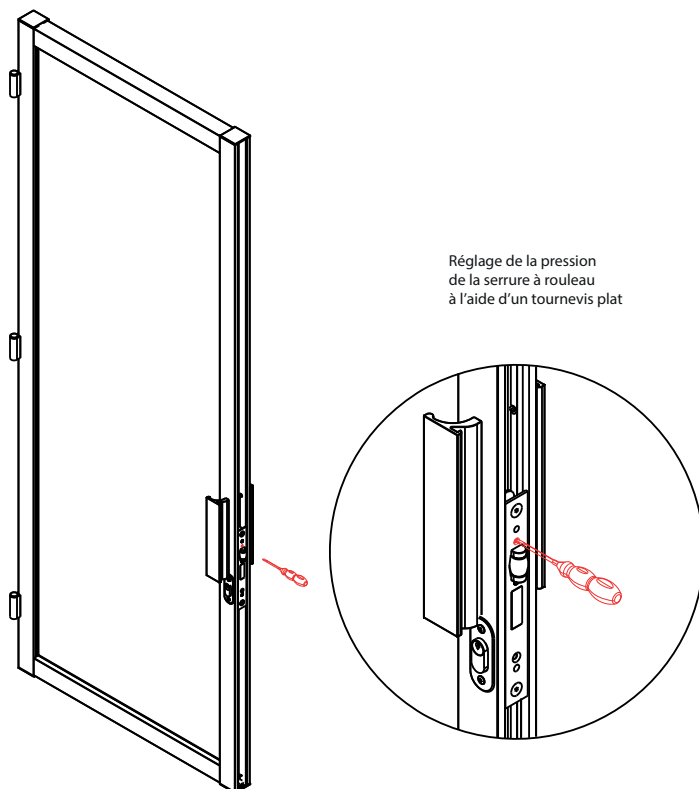



1 - Montage **serrure avec pêne dormant**

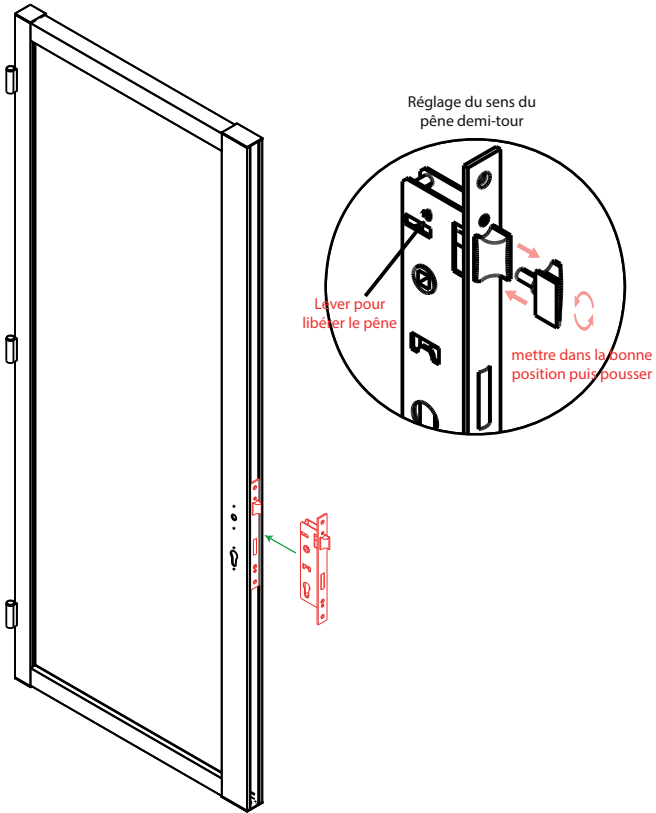

2 - Montage **cylindre**

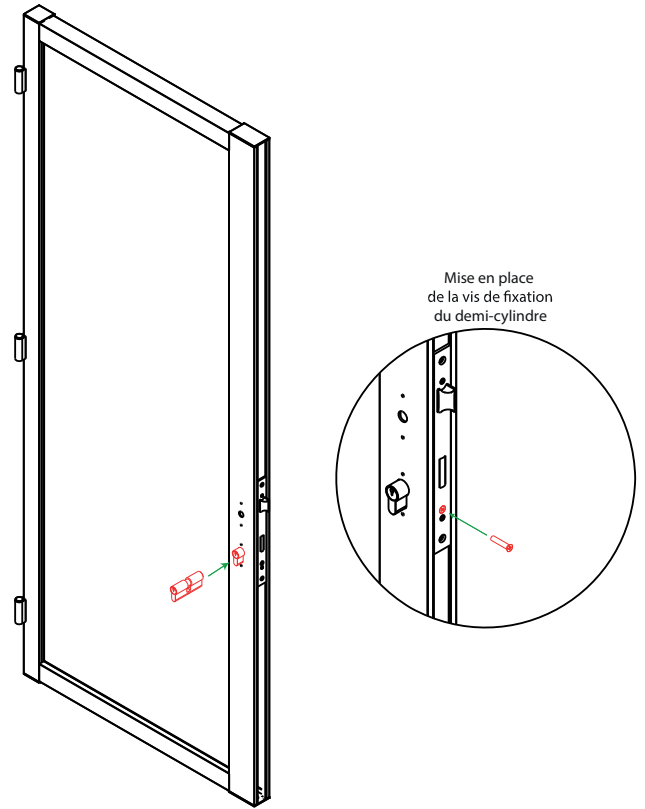

3 - Montage **béquilles + sous-rosaces**

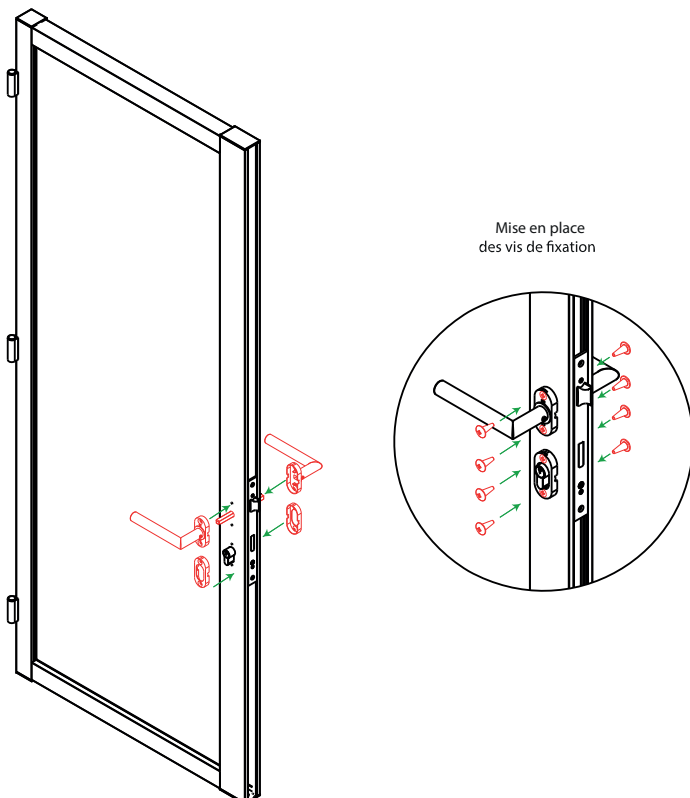

4 - Montage **des rosaces**

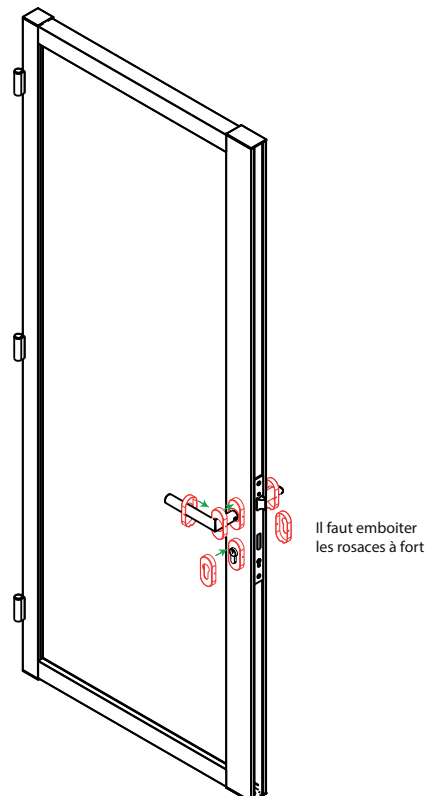



1 - Positionner et fixer l'assemblage **dormant**

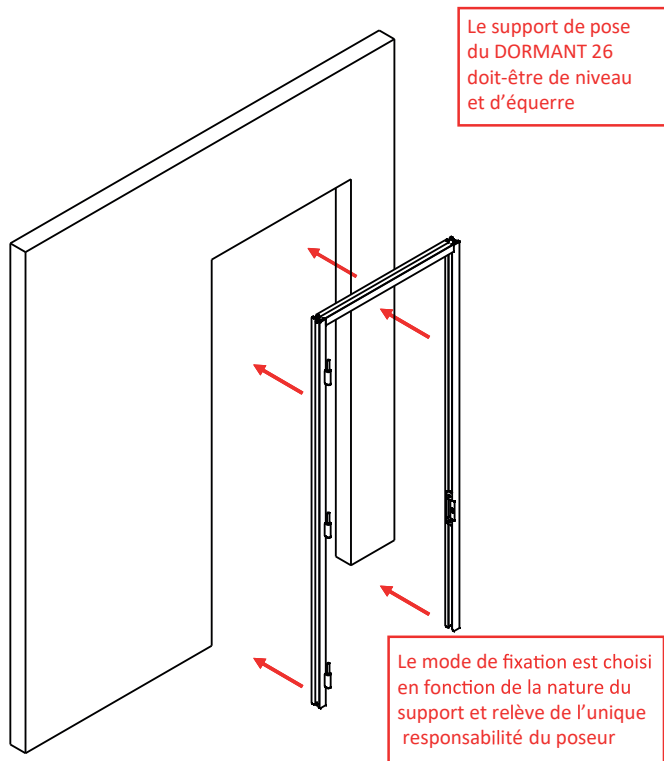

2 - Mise en place des CLIPS dans les **dormants**

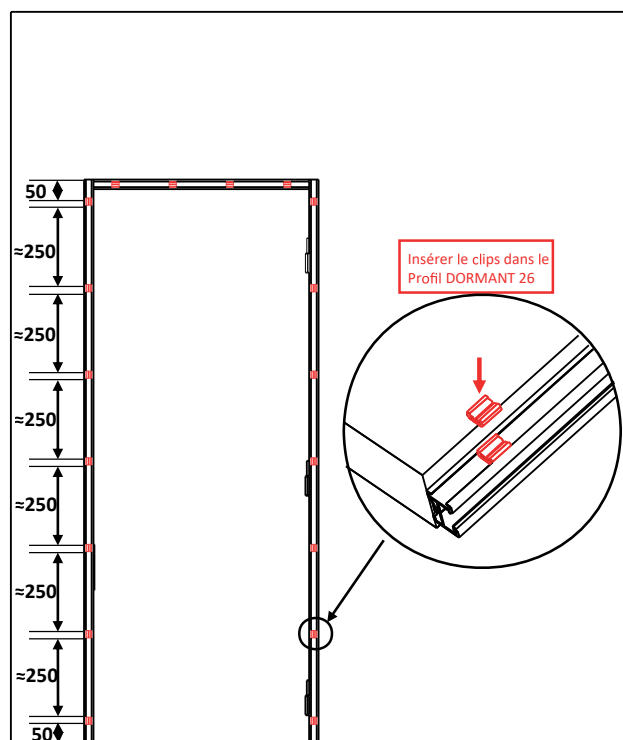

3 - Mise en place du joint **parcloses** dormant

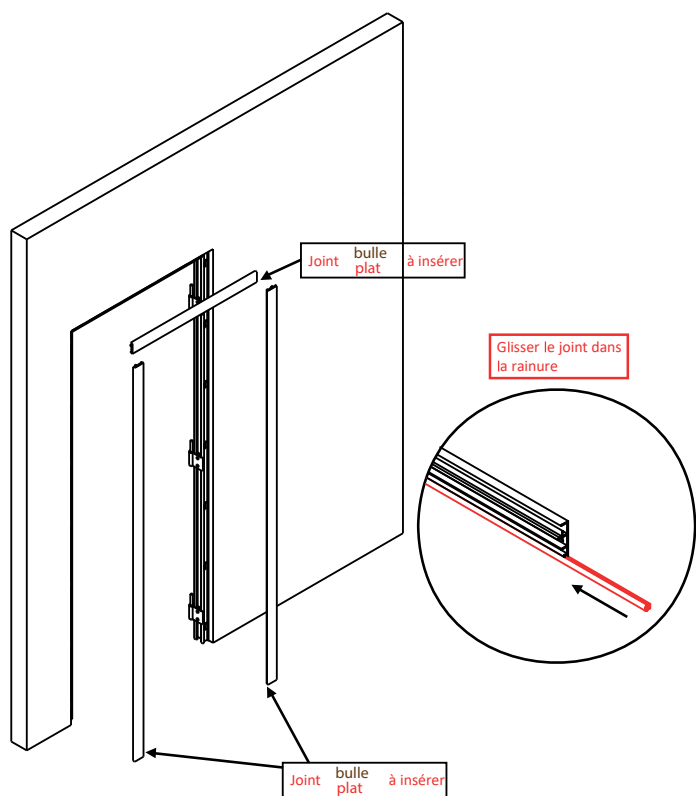

4 - Clipper les **parcloses**

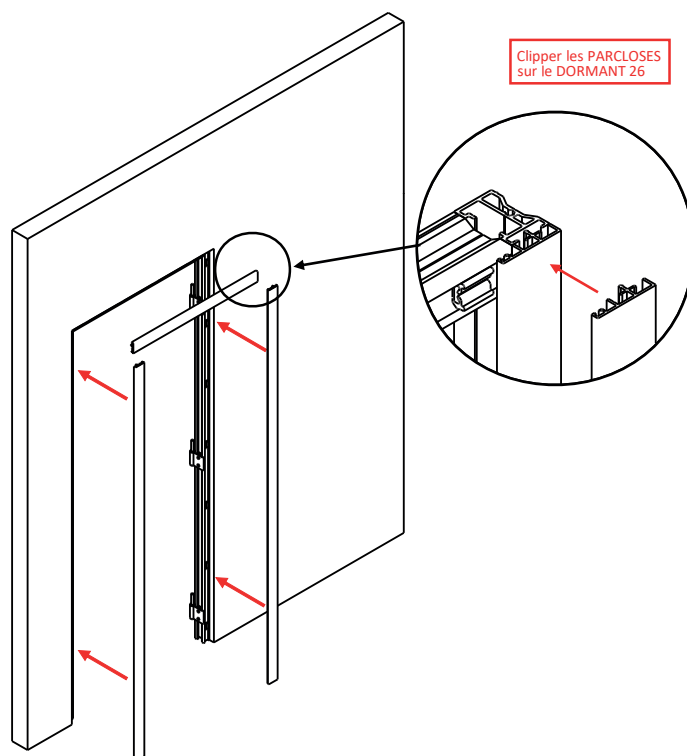



1 - Mise en place de la porte

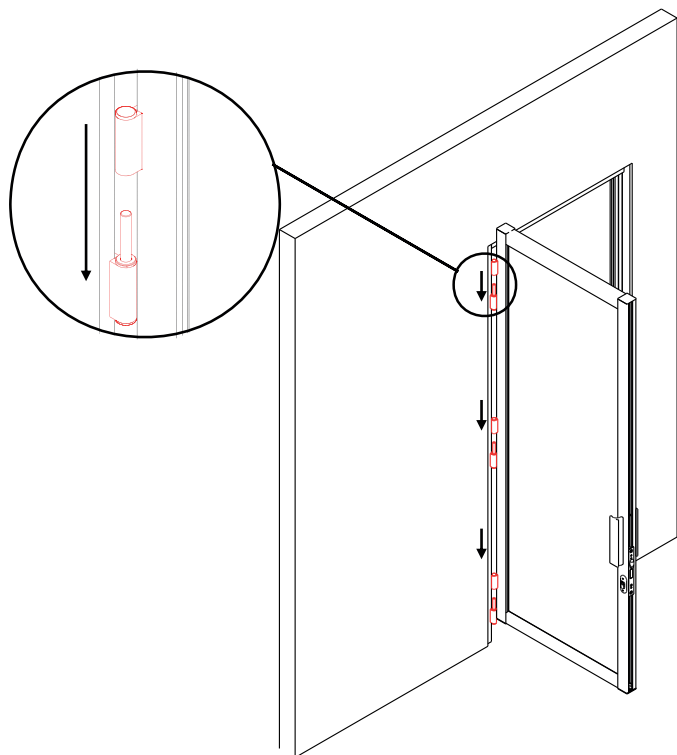

2 - Réglage Porte et Accessoires

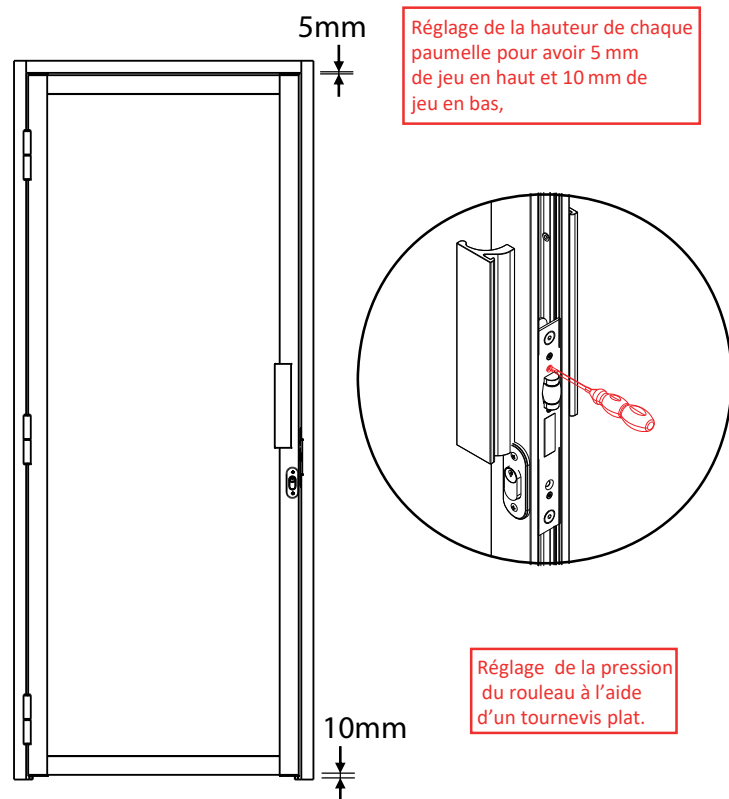

3 - Découpe à mesure des **plats de finition 23** (dormant)

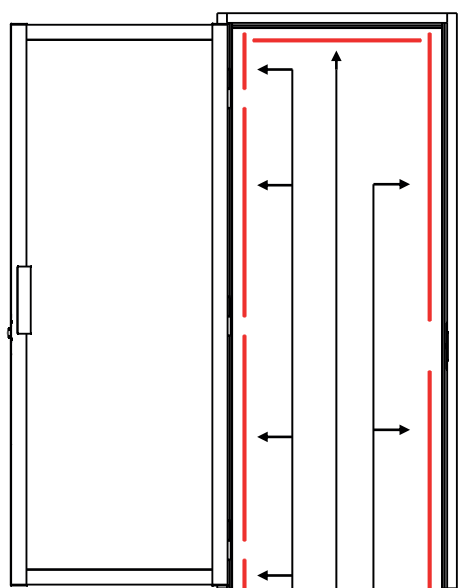

Découpe PLAT DE FINITION 23 pour DORMANT 26

4 - Découpe à mesure des **plats de finition 23** (Porte)

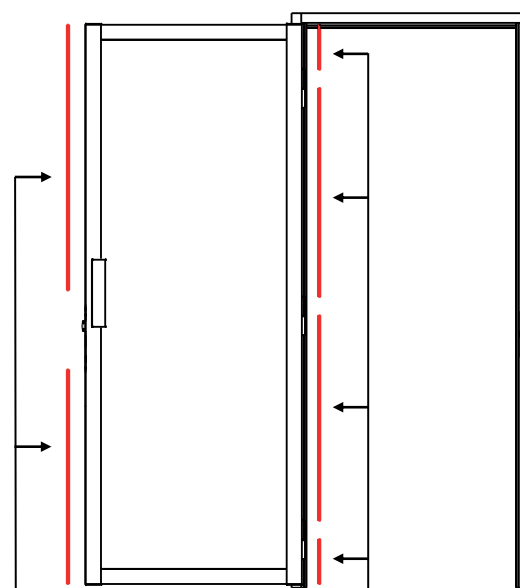

Découpe PLAT DE FINITION 23 pour PORTE OUVRANTE 40



**Porte avec poignée de tirage et serrure à rouleau**

ØPerçage Ø 9mm avant de monter les capots

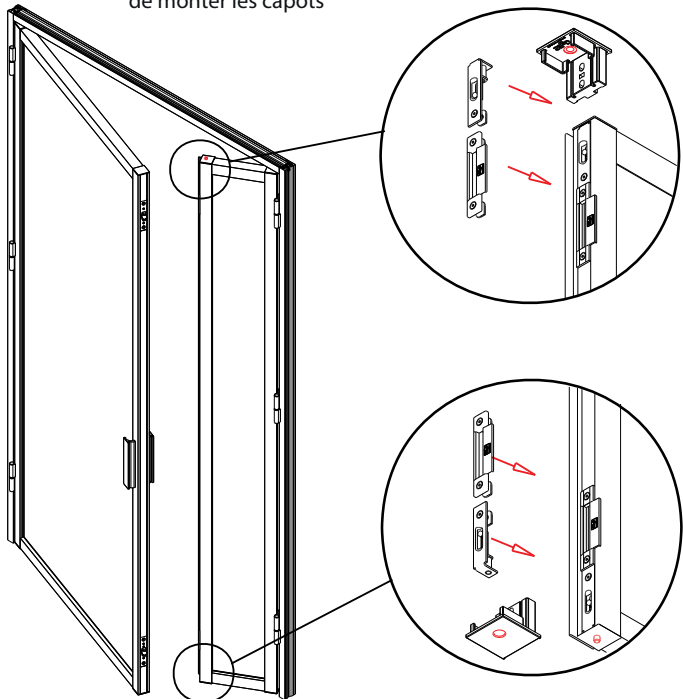

Nous préconisons de mettre 2 serrures à rouleau pour avoir des bons points de fermeture, Il est aussi possible de mettre 1 seul serrure à rouleau,

**Porte avec béquille**

ØPerçage Ø 9mm avant de monter les capots

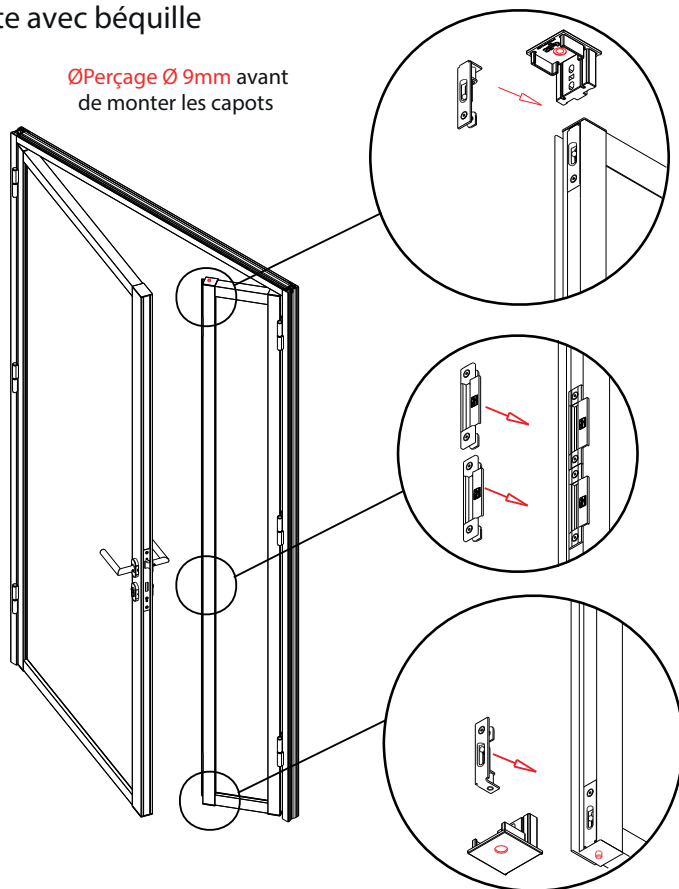

**Coller le plat 44**

Le plat 44 sert de couvre-joint entre les 2 portes

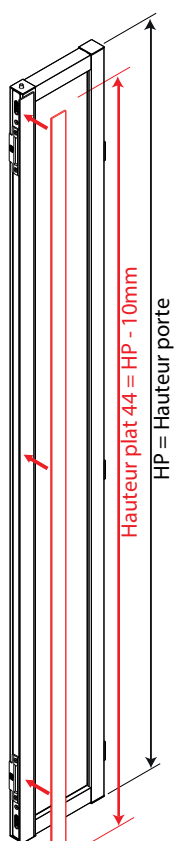
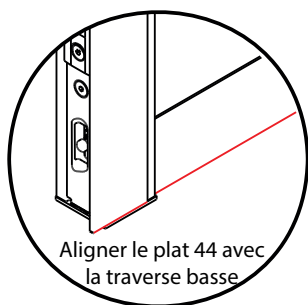
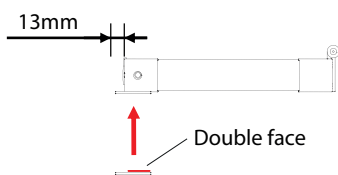

**Perçage du sol et du plat de finition**

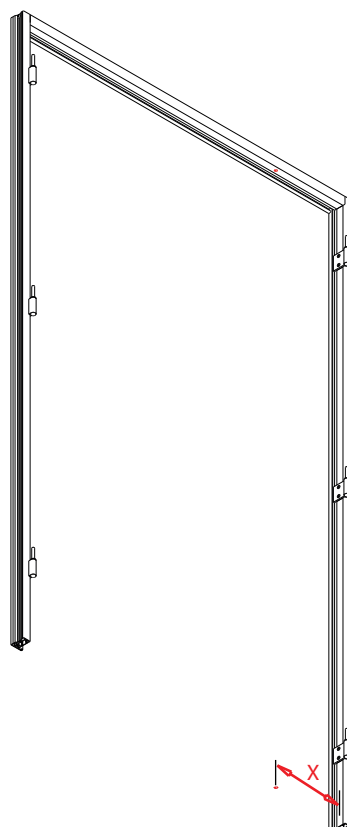

X = largeur porte tierce - 11mm  
Perçage Ø 9mm

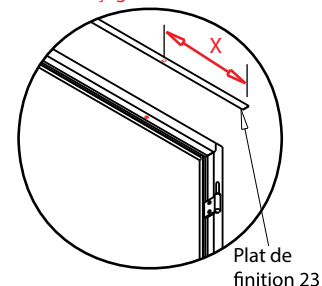

X = largeur porte tierce - 11mm  
Perçage dans le sol Ø 9mm  
profondeur 10mm



1 Perçage CADRE VERRIERE et DORMANT 26 (Ø 5mm)

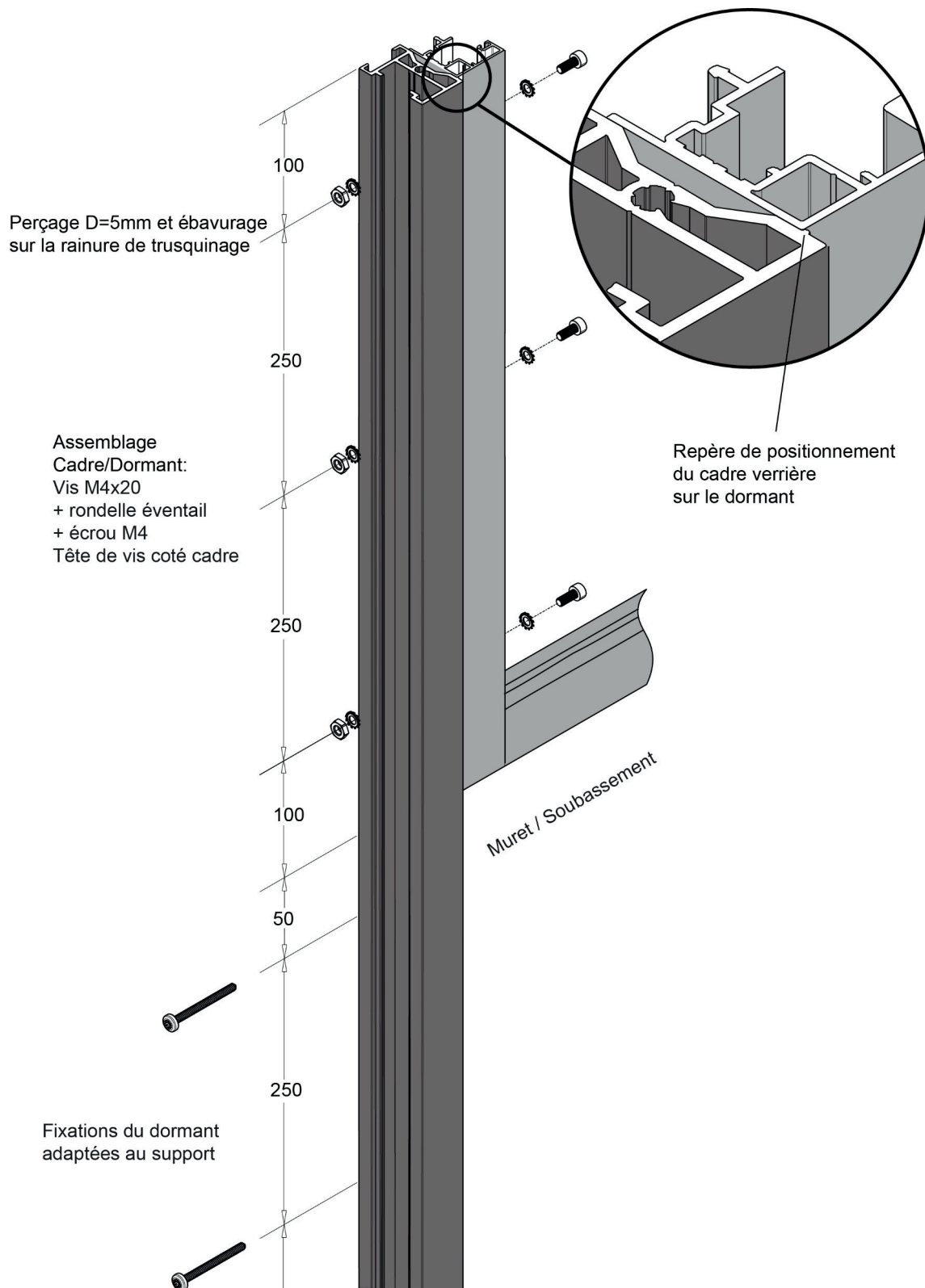





2 Limites et conditions d'installation (préconisées)

